



# Rotary Tiller

**MAK17**



# Rotary Tiller MAK17

## Technical Data

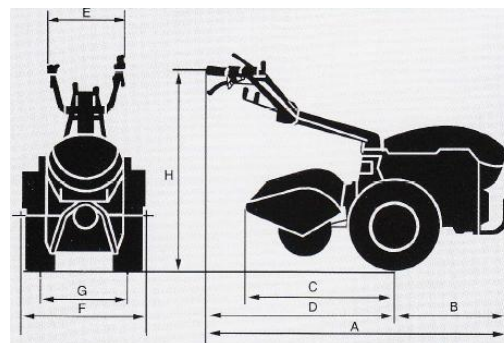

| Type              | A    | B   | C   | D    | E   | F       | G       | H        |
|-------------------|------|-----|-----|------|-----|---------|---------|----------|
| <b>MAK17 (mm)</b> | 2180 | 730 | 950 | 1450 | 580 | 600-900 | 420-510 | 600-1300 |

| Engine           |                          |
|------------------|--------------------------|
| Lombardini       | 3LD510                   |
| Type             | 1 cyl. / 4-stroke diesel |
| Displacement     | 510 cm <sup>3</sup>      |
| Engine output    | 9,0 kW (12 HP)           |
| Revolution speed | 3000/rpm                 |
| Starter          | Electric start           |
| Air filter       | oil-bath                 |
| Fuel filter      | gauze and filter element |

|               |                                  |
|---------------|----------------------------------|
| <b>Clutch</b> | Single, dry clutch friction disc |
|---------------|----------------------------------|

| Operational characteristics                     |  |
|---|--|
| Weight<br>(incl. tiller and tyres)              | 250 kg   |
| Working speed:<br>4 forward and 1 reverse gears |  |
| Tyres   | 6.50/80x12"  |
| Brakes  | with drum brakes (steering clutch brakes)  |
| Steering bar                                    | Steel tube bar on silent bearings 180° swivel height and side adjustment by hand |
| 2 x PTO shaft                                   | Standard PTO shaft with 2 speeds and independent PTO with reversing stop         |
| Differential                                    | with limited slip differential   |
| Safety  | Dead man's brake on steering bar   |
| Extra   | Trailer coupling and lights  |

### Optional accessories:

- Ridge Plow 180°
- Tiller 80cm (Standard) (adjustable 60cm) ; Tiller 90cm (adjustable 70cm)
- Rotary Sweeper 100cm pivoting brush roller diameter 38cm
- Bar Mower kpl. 122cm incl. Quickfit / 1 set replacement blades
- Snow Blade 100cm
- Flail mower 65cm or 85cm
- Drum/Rotary Mower 80cm 4 x rotary blades
- Sickle Mower 70cm or 80 cm
- Rotary Harrow 84cm
- Stoneburier 64cm incl. rear roller in expanded metal, depth adjustment and automatic slip clutch
- Snow Blower 80cm discharge throwing distance 10-15m
- Trailer max. Payload 350kg, dimensions platform: 1270x950x300mm, tyres 145x70-8
- Trailer max. Payload 500kg, dimensions platform: 1370x1200x300mm, tyres 155 R 13

Authorised dealer:



**PowerPac**  
**Baumaschinen GmbH**

Niederhöchstädter Str. 71-73 D-61476 Kronberg  
Tel.: 0049-(0)6173-68558 Fax: 0049-(0)6173-68548  
E-Mail: info@powerpac.de Internet: www.powerpac.de