



# Track-Dumper



snowblade



hydr. front loader



light cargo tray 600 ltr.

**RC 550**



# Track-Dumper RC 550

## Technical Data

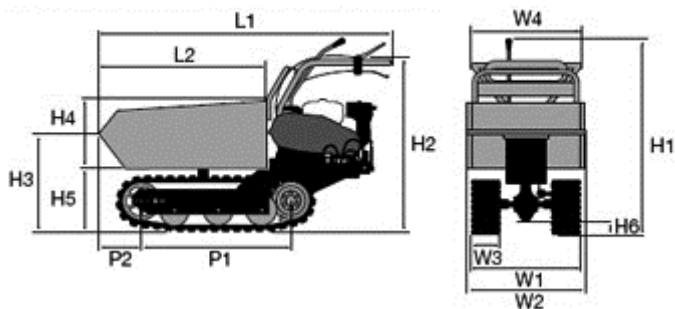

mm

L1	1575
L2	915
H1	1020
H2	900
H3	515-725
H4	405
H5	320
H6	70
W1	622
W2	622
W3	-
W4	620
P1	785
P2	265

<b>Engine</b>	
Honda	GX 160
Type	1 cyl. / 4-stroke
Displacement	160 cm <sup>3</sup>
Engine output	4,21 kW (5,5 HP)
Revolution speed	3600/rpm
Starter	reversing starter
Air filter	dry cell
Fuel filter	gauze

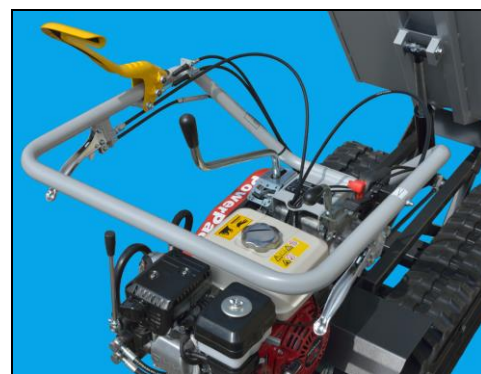

<b>Drive</b>	toothed gearing, shifting in oil-bath
<b>Brake</b>	automatic safety brake
<b>Guidance</b>	steering brake
<b>Characteristic</b>	hydraulic tipping device



<b>Operational characteristics</b>	
Weight	215 kg
Payload max.	550 kg
Tipping device	hydraulic
Climbing ability	max. 26° (50%)
Working speed	1,88 Km/h 1st gear forward 3,16 Km/h 2nd gear forward 4,13 Km/h 3rd gear forward 7,00 Km/h 4th gear forward 1,86 Km/h 1st gear reverse 3,13 Km/h 2nd gear reverse

hydraulic tipping



Authorised dealer:



**Baumaschinen GmbH**

Niederhöchstädter Str. 71-73 D-61476 Kronberg  
Tel.: 0049-(0)6173-68558 Fax: 0049-(0)6173-68548  
E-Mail: info@powerpac.de Internet: www.powerpac.de